

SECCIONADORES PARA FUSIBLES NH TAMAÑOS 1, 2 y 3 HASTA 630 A, 500 V

Modelo	Largo	Alto	Características		
			Luz indicadora fusible quemado	Conector doble	Cubre bornes
ACR630	200	115	no	no	no
ACR630F			si		
ACR630M			no	si	si
ACR630FM			si		

Accesorios opcionales	
Modelo	Descripción
ACRCA	apaga-chispas
ACRCB	cubre bornes

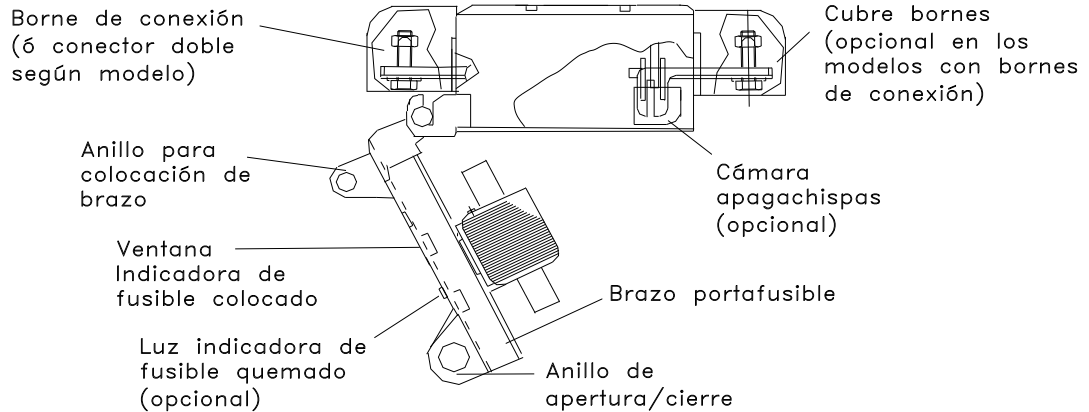

TIPOS DE FIJACION

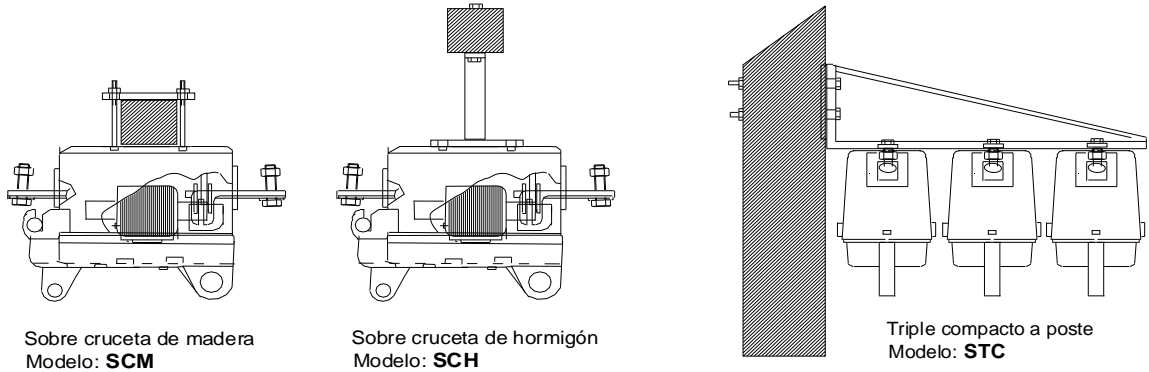

DETALLE DE OPERACIÓN

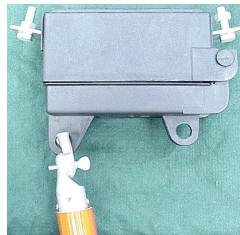

Apertura y cierre

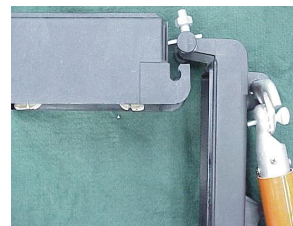

Colocación de brazo para cambio de fusibles